

TBP18S030, TBP18SA030
256 BITS (32 WORDS BY 8 BITS)
PROGRAMMABLE READ-ONLY MEMORIES

SDMS024 – SEPTEMBER 1979 – REVISED AUGUST 1984

- **Titanium-Tungsten (Ti-W) Fuse Link for Reliable Low-Voltage Full Family Compatible Programming**
- **Full Decoding and Fast Chip Select Simplify System Design**
- **P-N-P Inputs for Reduced Loading on System Buffers/Drivers**
- **Applications Include:**
 - Microprogramming/Firmware Loaders
 - Code Converters/Character Generators
 - Translators/Emulators
 - Address Mapping/Look-Up Tables
- **Choice of 3-State or Open-Collector Outputs**

TBP18SA030, TBP18S030 . . . J OR N PACKAGE
(TOP VIEW)

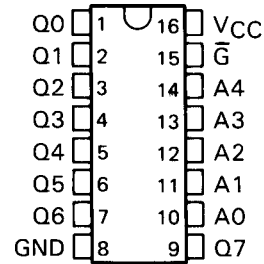

description

These monolithic TTL programmable read-only memories (PROMs) feature titanium-tungsten (Ti-W) fuse links with each link designed to program in 20 microseconds. The Schottky-clamped versions of these PROMs offer considerable flexibility for upgrading existing designs or improving new designs as they feature full Schottky clamping for improved performance, low-current MOS-compatible p-n-p inputs, choice of bus-driving three-state or open-collector outputs, and improved chip-select access times.

Data can be electronically programmed, as desired, at any bit location in accordance with the programming procedure specified. All PROMs are supplied with a low-logic level output condition stored at each bit location. The programming procedure open-circuits Ti-W metal links, which reverses the stored logic level at selected locations. The procedure is irreversible; once altered, the output for that bit location is permanently programmed. Outputs that have never been altered may later be programmed to supply the opposite output level. Operation of the unit within the recommended operating conditions will not alter the memory content.

A low level at the chip-select input(s) enables each PROM. The opposite level at any chip-select input causes the outputs to be off.

The three-state output offers the convenience of an open-collector with the speed of a totem-pole output; it can be bus-connected to other similar outputs yet it retains the fast rise time characteristic of the TTL totem-pole output. The open-collector output offers the capability of direct interface with a data line having a passive pull up.

A MJ suffix designates full-temperature circuits (formerly 54 Family) and are characterized for operation over the full military temperature range of -55°C to 125°C . A J or N suffix designates commercial-temperature circuits (formerly 74 Family) and are characterized for operation from 0°C to 70°C .

TBP18S030, TBP18SA030 256 BITS (32 WORDS BY 8 BITS) PROGRAMMABLE READ-ONLY MEMORIES

SDMS024 – SEPTEMBER 1979 – REVISED AUGUST 1984

logic symbol

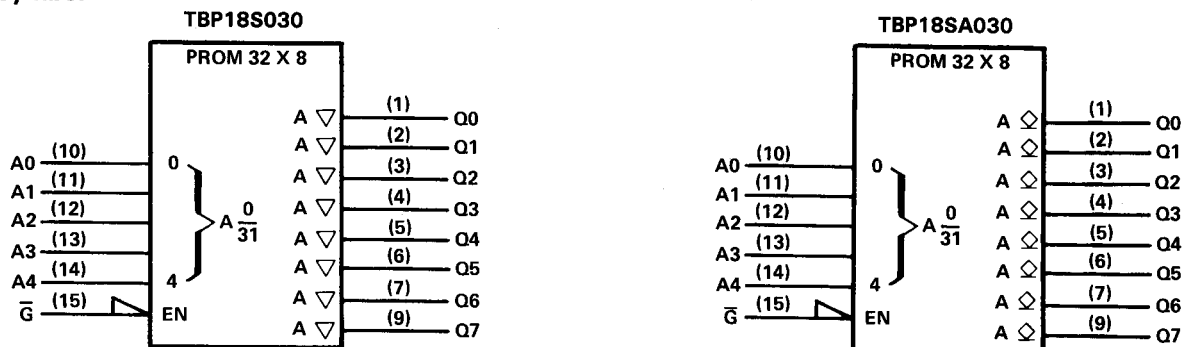

schematics of inputs and outputs

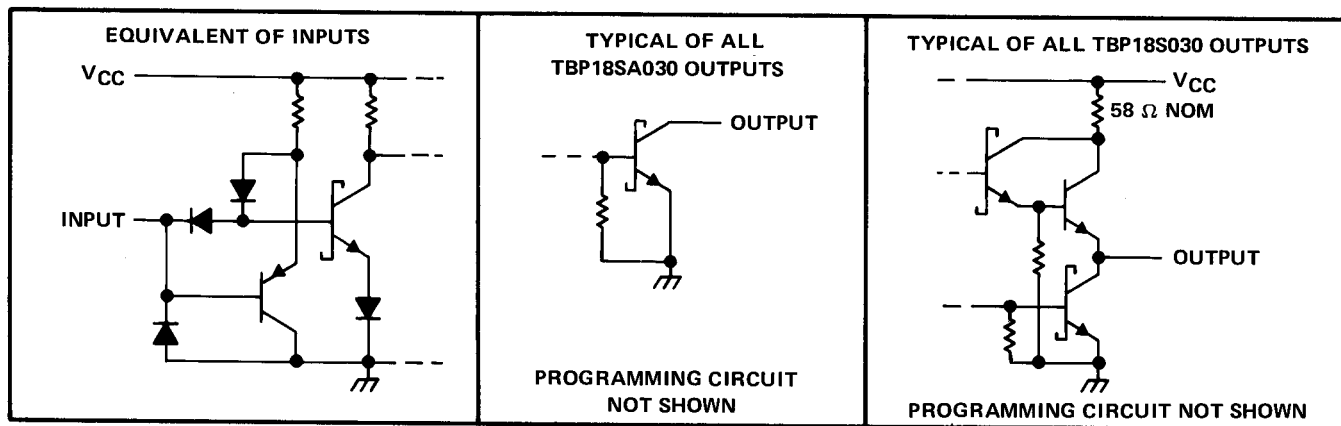

absolute maximum ratings over operating free-air temperature range (unless otherwise noted)

Supply voltage (see Note 1)	7V
Input voltage	5.5V
Off-state output voltage	5.5V
Operating free-air temperature range: Full-temperature-range circuits	-55°C to 125°C
Commercial-temperature-range circuits	0°C to 70°C
Storage temperature range	-65°C to 150°C

recommended conditions for programming TBP18S', TBP18SA PROMs

		MIN	NOM	MAX	UNIT
Supply voltage, V_{CC} (see Note 1)	Steady state	4.75	5	5.25	V
	Program pulse	9	9.25	9.5	
Input voltage	High level, V_{IH}	2.4		5	V
	Low level, V_{IL}	0		0.5	
Termination of all outputs except the one to be programmed		See load circuit (Figure 1)			
Voltage applied to output to be programmed, $V_{O(pr)}$ (see Note 2)		0	0.25	0.3	V
Duration of V_{CC} programming pulse X (see Figure 2 and Note 3)		15	25	100	μs
Programming duty cycle for Y pulse			25	35	%
Free-air temperature		20	25	30	°C

NOTES: 1. Voltage values are with respect to network ground terminal. The supply voltage rating does not apply during programming.
2. The TBP18S030, TBP18SA030 are supplied with all bit locations containing a low logic level, and programming a bit changes the output of the bit to high logic level.



programming procedure

1. Apply steady-state supply voltage ($V_{CC} = 5\text{ V}$) and address the word to be programmed.
2. Verify that the bit location needs to be programmed. If not, proceed to the next bit.
3. If the bit requires programming, disable the outputs by applying a high-logic level voltage to the chip-select input(s).
4. Only one bit location is programmed at a time. Connect each output not being programmed to 5 V through 3.9 k Ω and apply the voltage specified in the table to the output to be programmed. Maximum current into the programmer output is 150 mA.
5. Step V_{CC} to 9.25 nominal. Maximum supply current required during programming is 750 mA.
6. Apply a low-logic-level voltage to the chip-select input(s). This should occur between 1 μs and 1 ms after V_{CC} has reached its 9.25 level. See programming sequence of Figure 2.
7. After the X pulse time is reached, a high logic level is applied to the chip-select inputs to disable the outputs.
8. Within the range of 1 μs to 1 ms after the chip-select input(s) reach a high logic level, V_{CC} should be stepped down to 5 V at which level verification can be accomplished.
9. The chip-select input(s) may be taken to a low logic level (to permit program verification) 1 μs or more after V_{CC} reaches its steady-state value of 5 V.
10. At a Y pulse duty cycle of 35% or less, repeat steps 1 through 8 for each output where it is desired to program a bit.
11. Verify accurate programming of every word after all words have been programmed using V_{CC} values of 4.5 and 5.5 volts.

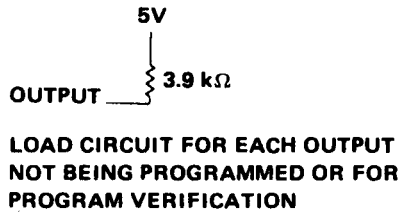

FIGURE 1 – LOAD CIRCUIT

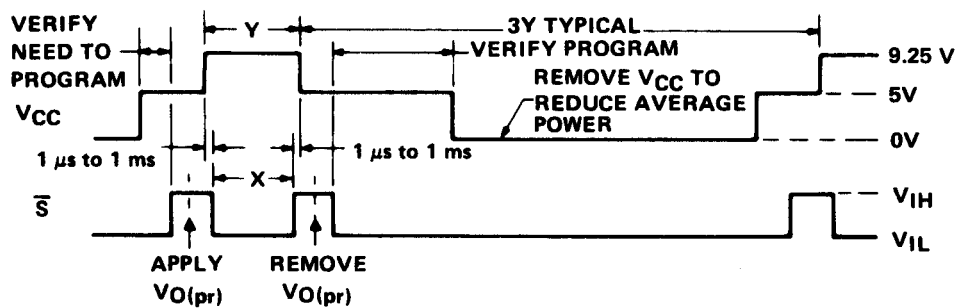

FIGURE 2 – VOLTAGE WAVEFORMS FOR PROGRAMMING

TBP18S030, TBP18SA030
256 BITS (32 WORDS BY 8 BITS)
PROGRAMMABLE READ-ONLY MEMORIES

SDMS024 – SEPTEMBER 1979 – REVISED AUGUST 1984

recommended operating conditions (see Note 4)

PARAMETER		TBP18S030			UNIT
		MIN	NOM	MAX	
Supply voltage, V_{CC}	MJ	4.5	5	5.5	V
	J, N	4.75	5	5.25	
High-level output current, I_{OH}	MJ			-2	mA
	J, N			-6.5	
Low-level output current, I_{OL}				20	mA
Operating free-air temperature, T_A	MJ	-55		125	°C
	J, N	0		70	

electrical characteristics over recommended operating free-air temperature range (unless otherwise noted) (see Note 4)

PARAMETER	TEST CONDITIONS†	FULL TEMP (MJ)			COMM. TEMP (J, N)			UNIT
		MIN	TYP‡	MAX	MIN	TYP‡	MAX	
V_{IH} High-level input voltage		2			2			V
V_{IL} Low-level input voltage		0.8			0.8			V
V_{IK} Input clamp voltage	$V_{CC} = \text{MIN}, I_I = -18 \text{ mA}$	-1.2			-1.2			V
V_{OH} High-level output voltage	$V_{CC} = \text{MIN}, V_{IH} = 2 \text{ V}, V_{IL} = 0.8 \text{ V}, I_{OH} = \text{MAX}$	2.4	3.4		2.4	3.2		V
V_{OL} Low-level output voltage	$V_{CC} = \text{MIN}, V_{IH} = 2 \text{ V}, V_{IL} = 0.8 \text{ V}, I_{OL} = \text{MAX}$	0.5			0.5			V
I_{OZH} Off-state output current, high-level voltage applied	$V_{CC} = \text{MAX}, V_{IH} = 2 \text{ V}, V_O = 2.4 \text{ V}$	50			50			μA
I_{OZL} Off-state output current, low-level voltage applied	$V_{CC} = \text{MAX}, V_{IH} = 2 \text{ V}, V_O = 0.5 \text{ V}$	-50			-50			μA
I_I Input current at maximum input voltage	$V_{CC} = \text{MAX}, V_I = 5.5 \text{ V}$	1			1			mA
I_{IH} High-level input current	$V_{CC} = \text{MAX}, V_I = 2.7 \text{ V}$	25			25			μA
I_{IL} Low-level input current	$V_{CC} = \text{MAX}, V_I = 0.5 \text{ V}$	-0.25			-0.25			mA
I_{OS} Short-circuit output current§	$V_{CC} = \text{MAX}$	-30		-100	-30		-100	mA
I_{CC} Supply current	$V_{CC} = \text{MAX}$, Chip select(s) at 0 V, Outputs open, See Note 5		80	110		80	110	mA

switching characteristics over recommended ranges of T_A and V_{CC} (unless otherwise noted)

TYPE	TEST CONDITIONS	$t_a(\text{A})$ ACCESS TIME FROM ADDRESS			$t_a(\text{S})$ ACCESS TIME FROM CHIP SELECT (ENABLE TIME)			t_{dis} DISABLE TIME FROM HIGH OR LOW LEVEL			UNIT
		MIN	TYP‡	MAX	MIN	TYP‡	MAX	MIN	TYP‡	MAX	
TBP18S030MJ	$C_L = 30 \text{ pF}$ for $t_a(\text{A})$ and $t_a(\text{S})$,		25	50		12	30		8	30	ns
TBP18S030	5 pF for t_{dis} , See Note 6		25	40		12	25		8	20	ns

†For conditions shown as MIN or MAX, use the appropriate value specified under recommended operating conditions.

‡All typical values are at $V_{CC} = 5 \text{ V}, T_A = 25^\circ\text{C}$.

§Not more than one output should be shorted at a time and duration of the short circuit should not exceed one second.

NOTES: 4. MJ designates full-temperature circuits (formerly 54 Family), J and N designate commercial-temperature circuits (formerly 74 Family).

5. The typical values of I_{CC} are with all outputs low.



TBP18S030, TBP18SA030
256 BITS (32 WORDS BY 8 BITS)
PROGRAMMABLE READ-ONLY MEMORIES

SDMS024 – SEPTEMBER 1979 – REVISED AUGUST 1984

recommended operating conditions (see Note 4)

PARAMETER		TBP18SA030			UNIT
		MIN	NOM	MAX	
Supply voltage, V_{CC}	MJ	4.5	5	5.5	V
	J, N	4.75	5	5.25	
High-level output voltage, V_{OH}				5.5	V
Low-level output current, I_{OL}				20	mA
Operating free-air temperature, T_A	MJ	-55		125	°C
	J, N	0		70	

electrical characteristics over recommended operating free-air temperature range (unless otherwise noted)

PARAMETER	TEST CONDITIONS†	MIN	TYP‡	MAX	UNIT	
V_{IH} High-level input voltage		2			V	
V_{IL} Low-level input voltage				0.8	V	
V_{IK} Input clamp voltage	$V_{CC} = \text{MIN}$, $I_I = -18\text{mA}$			-1.2	V	
I_{OH} High-level output current	$V_{CC} = \text{MIN}$, $V_{IH} = 2\text{V}$, $V_{IL} = 0.8\text{V}$			$V_{OH} = 2.4\text{V}$	50	μA
				$V_{OH} = 5.5\text{V}$	100	
V_{OL} Low-level output voltage	$V_{CC} = \text{MIN}$, $V_{IL} = 0.8\text{V}$, $V_{IH} = 2\text{V}$, $I_{OL} = \text{MAX}$			0.5	V	
I_I Input current at maximum input voltage	$V_{CC} = \text{MAX}$, $V_I = 5.5\text{V}$			1	mA	
I_{IH} High-level input current	$V_{CC} = \text{MAX}$, $V_I = 2.7\text{V}$			25	μA	
I_{IL} Low-level input current	$V_{CC} = \text{MAX}$, $V_I = 0.5\text{V}$			-0.25	mA	
I_{CC} Supply current	$V_{CC} = \text{MAX}$, Chip select(s) at 0 V, Outputs open, See Note 5		80	110	mA	

switching characteristics over recommended ranges of T_A and V_{CC} (unless otherwise noted)

TYPE	TEST CONDITIONS	$t(A)$ ACCESS TIME FROM ADDRESS			$t_a(S)$ ACCESS TIME FROM CHIP SELECT (ENABLE TIME)			t_{PLH} PROPAGATION DELAY TIME, LOW-TO-HIGH-LEVEL OUTPUT FROM CHIP SELECT (DISABLE TIME)			UNIT
		MIN	TYP‡	MAX	MIN	TYP‡	MAX	MIN	TYP‡	MAX	
TBP18SA030MJ	$C_L = 30\text{pF}$, $R_{L1} = 300\ \Omega$,		25	50		12	30		12	30	ns
TBP18SA030	$R_{L2} = 600\ \Omega$, See Note 6		25	40		12	25		12	25	ns

†For conditions shown as MIN or MAX, use the appropriate value specified under recommended operating conditions.

‡All typical values are at $V_{CC} = 5\text{V}$, $T_A = 25^\circ\text{C}$.

NOTES: 4. MJ designates full-temperature circuits (formerly 54 Family), J and N designate commercial-temperature circuits (formerly 74 Family).

5. The typical values of I_{CC} are with all outputs low.

6. Load circuits and voltage waveforms are shown in Section 1.



IMPORTANT NOTICE

Texas Instruments and its subsidiaries (TI) reserve the right to make changes to their products or to discontinue any product or service without notice, and advise customers to obtain the latest version of relevant information to verify, before placing orders, that information being relied on is current and complete. All products are sold subject to the terms and conditions of sale supplied at the time of order acknowledgment, including those pertaining to warranty, patent infringement, and limitation of liability.

TI warrants performance of its products to the specifications applicable at the time of sale in accordance with TI's standard warranty. Testing and other quality control techniques are utilized to the extent TI deems necessary to support this warranty. Specific testing of all parameters of each device is not necessarily performed, except those mandated by government requirements.

Customers are responsible for their applications using TI components.

In order to minimize risks associated with the customer's applications, adequate design and operating safeguards must be provided by the customer to minimize inherent or procedural hazards.

TI assumes no liability for applications assistance or customer product design. TI does not warrant or represent that any license, either express or implied, is granted under any patent right, copyright, mask work right, or other intellectual property right of TI covering or relating to any combination, machine, or process in which such products or services might be or are used. TI's publication of information regarding any third party's products or services does not constitute TI's approval, license, warranty or endorsement thereof.

Reproduction of information in TI data books or data sheets is permissible only if reproduction is without alteration and is accompanied by all associated warranties, conditions, limitations and notices. Representation or reproduction of this information with alteration voids all warranties provided for an associated TI product or service, is an unfair and deceptive business practice, and TI is not responsible nor liable for any such use.

Resale of TI's products or services with statements different from or beyond the parameters stated by TI for that product or service voids all express and any implied warranties for the associated TI product or service, is an unfair and deceptive business practice, and TI is not responsible nor liable for any such use.

Also see: [Standard Terms and Conditions of Sale for Semiconductor Products](http://www.ti.com/sc/docs/stdterms.htm). www.ti.com/sc/docs/stdterms.htm

Mailing Address:

Texas Instruments
Post Office Box 655303
Dallas, Texas 75265

PRODUCT FOLDER | PRODUCT INFO: [FEATURES](#) | [DESCRIPTION](#) | [DATASHEETS](#) | [PRICING/AVAILABILITY/PKG](#) | [APPLICATION NOTES](#) | [USER GUIDES](#) | [MORE LITERATURE](#)

JBP18S030, 32X8 Bi-Polar PROMDEVICE STATUS: **ACTIVE**

PARAMETER NAME	JBP18S030
Voltage Node (nom) (V)	5

FEATURES[▲Back to Top](#)

- Titanium-Tungsten (Ti-W) Fuse Link for Reliable Low-Voltage Full Family Compatible Programming
- Full Decoding and Fast Chip Select Simplify System Design
- P-N-P Inputs for Reduced Loading on System Buffers/Drivers
- Applications Include:
 - Microprogramming/Firmware Loaders
 - Code Converters/Character Generators
 - Translators/Emulators
 - Address Mapping/Look-Up Tables
- Choice of 3-State or Open-Collector Outputs

DESCRIPTION[▲Back to Top](#)

These monolithic TTL programmable read-only memories (PROMs) feature titanium-tungsten (Ti-W) fuse links with each link designed to program in 20 microseconds. The Schottky-clamped versions of these PROMs offer considerable flexibility for upgrading existing designs or improving new designs as they feature full Schottky clamping for improved performance, low-current MOS-compatible p-n-p inputs, choice of bus-drive three-state or open-collector outputs, and improved chip-select access times.

Data can be electronically programmed, as desired, at any bit location in accordance with the programming procedure specified. All PROMs are supplied with a low-logic level output condition stored at each bit location. The programming procedure open-circuits Ti-W metal links, which reverses the stored logic level at selected locations. The procedure is irreversible; once altered, the output for that bit location is permanently programmed. Outputs that have never been altered may later be programmed to supply the opposite output level. Operation of the unit within the recommended operating conditions will not alter the memory content.

A low level at the chip-select input(s) enables each PROM. The opposite level at any chip-select input causes the outputs to be off.

The three-state output offers the convenience of an open-collector with the speed of the totem-pole output; it can be bus-connected to other similar outputs yet it retains the fast rise time characteristic of the TTL totem-pole output. The open-collector offers the capability of direct interface with a data line having a passive pull up.

A MJ suffix designates full-temperature circuits (formerly 54 family) and are characterized for operation over the full military temperature range of -55°C to 125°C. A J or N suffix designates commercial-temperature circuits (formerly 74 family) and are characterized for operation from 0°C to 70°C.

TECHNICAL DOCUMENTS[▲Back to Top](#)

To view the following documents, [Acrobat Reader 4.0](#) is required.

To download a document to your hard drive, right-click on the link and choose 'Save'.

DATASHEET[▲Back to Top](#)

Full datasheet in Acrobat PDF: [jbp18s030.pdf](#) (247 KB) (Updated: 08/01/1984)

APPLICATION NOTES[▲Back to Top](#)

View Application Notes for [Digital Logic](#)

- [Evaluation of Nickel/Palladium/Gold-Finished Surface-Mount Integrated Circuits \(SZZA026 - Updated: 06/20/2001\)](#)
- [Understanding and Interpreting Texas Instruments Standard-Logic Products Data Sh \(Rev. A\) \(SZZA036A - Updated: 02/27/2003\)](#)

MORE LITERATURE

[▲Back to Top](#)

- [Enhanced Plastic Portfolio Brochure \(SGZB004, 387 KB - Updated: 08/19/2002\)](#)
- [Logic Reference Guide \(SCYB004, 1032 KB - Updated: 10/23/2001\)](#)
- [MicroStar Junior BGA Design Summary \(SCET004, 167 KB - Updated: 07/28/2000\)](#)
- [Military Brief \(SGYN138, 803 KB - Updated: 10/10/2000\)](#)
- [Overview of IEEE Std 91-1984, Explanation of Logic Symbols Training Booklet \(Rev. A\) \(SDYZ001A, 138 KB - Updated: 07/01/1996\)](#)
- [Palladium Lead Finish User's Manual \(SDYV001, 2041 KB - Updated: 11/01/1996\)](#)
- [QML Class V Space Products Military Brief \(Rev. A\) \(SGZN001A, 257 KB - Updated: 10/07/2002\)](#)

USER GUIDES

[▲Back to Top](#)

- [LOGIC Pocket Data Book \(SCYD013, 4837 KB - Updated: 12/05/2002\)](#)

PRICING/AVAILABILITY/PKG

[▲Back to Top](#)

DEVICE INFORMATION Updated Daily								TI INVENTORY STATUS As Of 08:00 AM GMT, 17 Apr 2003			REPORTED DISTRIBUTOR INVENTORY As Of 08:00 AM GMT, 17 Apr 2003		
ORDERABLE DEVICE	STATUS	PACKAGE TYPE PINS	TEMP (°C)	DSCC NUMBER	PRODUCT CONTENT	BUDGETARY PRICING QTY SUS	STD PACK QTY	IN STOCK	IN PROGRESS QTY DATE	LEAD TIME	DISTRIBUTOR COMPANY REGION	IN STOCK	PURCHASE
JBP18S030MJ	ACTIVE	CDIP (J) 16	-55 TO 125		View Contents	1KU 16.22	1	0*	100 12 May	5 WKS	Avnet Americas	37	BUY NOW
									> 10k 20 May				
JBP18S030MW	ACTIVE	CFP (W) 16	-55 TO 125		View Contents	1KU 27.03	1	0*	> 10k 20 May	5 WKS	None Reported View Distributors		

Table Data Updated on: 4/17/2003

[Products](#) | [Applications](#) | [Support](#) | [my.TI](#)